

NON-ISOTHERMAL REACTION ANALYSIS AND ARTIFICIAL INTELLIGENCE—A PROMISING COMBINATION FOR KINETIC STUDIES USING THERMOANALYTICAL METHODS *

E. KOCH

Max-Planck-Institut für Strahlenchemie, Stiftstr. 34–36, D-4330 Mülheim a.d. Ruhr (F.R.G.)

(Received 30 October 1986; in final form 19 January 1987)

ABSTRACT

Applications of the computer to various problems in the evaluation of TA records, obtained by DTA or UV reaction spectroscopy, are discussed with a view to model searches, preferentially in homogeneous kinetics, and are compared with chess computer strategies. For all TA methods based on proportionality between the temporary kinetic flux and signal amplitude, mechanistic codes can be calculated which allow comparison with elaborated theoretical codes of basic reaction mechanisms. All sources needed for a model-search program, and the complete set of such concentration codes for two-step models are presented, with a view to the differences between the codes of elementary reactions.

A self-learning expert system, inducing both creation and study of new basic material, should be more effective than the tedious reproduction of the signals of individual experiments by fitting the respective activation and signal parameters, using various arbitrarily assumed models.

INTRODUCTION

The term “Non-isothermal Reaction Analysis” was introduced by the author [1] in order to discuss such methods, based on a temperature program, which are intended to study reactions rather than substances. In an experiment, reaction steps are characterized by both the total change of the detected physical quantity (e.g. reaction enthalpy, weight loss, extinction change) and by the time dependence of this change, i.e. the kinetics, described by the activation parameters. Hence, the term Reaction Analysis includes more than just reaction kinetics.

The general importance of time evolutions in our complex world of interactions suggests the consideration of Reaction Analysis as a special branch of Systems Analysis, dealing with the testing of models and their extrapolation to the future (cf. the study of world models [2]). Studies of

* Dedicated to Prof. W.W. Wendlandt on the occasion of his 60th birthday.

complex systems following such intentions need a corresponding mathematical background, including at least Information Theory, the Theory of Differential Equations, dealing just with the time evolutions, and Set Theory. For the optimum coordination and survey of the developments of those complex interrelations, human thinking capability will soon become insufficient; this is also the reason for the impact of computers in Thermal Analysis [3–6].

Returning to chemistry, it is obvious that the thermoanalytical methods are the best for Reaction Analysis: They are capable of involving and reflecting knowledge on temperature influences, represented by the activation parameters, even in one experiment. Moreover, the usually preferred linear temperature program reduces the barrier for a pragmatic mathematical approach. In mass-action kinetics, complex reaction mechanisms may be better understood when linear superpositions of elementary effects can be provided, as in other fields of science (e.g. Perturbation Theory).

In this paper, the central problem of “inverse reaction kinetics” [7,8], i.e. model search for a reacting system, is the main subject of discussion. Non-isothermal Reaction Analysis, in its most useful form represented by DTA and DSC, allows nearly all “slow” one-step reactions in solution to be characterized by a few experiments. Hence, it is only a problem of organization to create the obligatory kinetic data tables of chemical processes [3,6]. Since it involves knowledge of special signal parameters from previous or parallel isotherm studies, a satisfactory solution of the model-search problem would even allow a general classification of complex reactions by indicating the mode of degradation into elementary processes. Necessary foundations for the development of an expert system revealing this “reaction mechanism” are listed and discussed.

ELEMENTARY PROCESSES

Fundamentals

The constituent elements of any reaction mechanism are the bimolecular processes, which involve first- and second-order reactions as limiting cases. The theory of relationships between activation parameters, shape and time/temperature position of the corresponding rate signal, has recently been completed both by computer calculations and numerous experiments [9,10]. Therefore, in the case of known activation data, the signals can be predicted, i.e. thermoanalytical experiments can be planned more effectively and their results may be understood more easily.

Essential progress in this field has evolved from the “Theory of Characteristic Rate Coefficients” [9–13], first discussed in detail by the author [14–16]. From the Arrhenius equation it can be deduced that for reaction

kinetics at constant temperature increase, any elementary reaction is determined by both a characteristic temperature, such as the peak temperature T_m , and the specific time u , which is for a heating rate m given by

$$u = \frac{E}{mR(\ln k_\infty + \ln u)^2} = \frac{R}{mE} T_m^2 \approx \frac{\int_0^\infty k(mt) dt}{k_m} \quad (1)$$

where E = activation energy, k_∞ = A -factor, k_m = rate coefficient at signal maximum and R = gas constant. At measuring conditions of thermal analysis, the specific temperatures, given by the product $w = m u$, are proportional to the halfwidth of the signal, and for "slow" reactions in solution usually accumulated in the range 2–15 K [17]. For the rate maximum of a first-order process, the product of specific time with the rate coefficient, uk , is simply given by unity, if the admissible approximation of constant u in the measuring range is applied. Analogously, for all uni- and bi-molecular reactions, such products uk at other characteristic points of the signal (such as onset, halfwidth and inflection points, end point) are constant and independent of the activation parameters. Only in the bimolecular case do they depend on the initial concentrations of the reactants and, at onset and end, on the relative minimum rate [10–12,14]. All the corresponding characteristic times and temperatures are approximately available from u , k_m , the activation parameters, and the reaction order n . The occurrence of such characteristic products uk has a strict analogy in isothermal kinetics if u and $k(mt)$ are substituted by a (constant) k and $t - t_0$.

Characteristic temperature differences

A further consequence of the Theory of Characteristic Rate Coefficients is the existence of a reaction type index M , based on the Arrhenius equation and the product uk at the signal maximum, and defined as [18,19]

$$M = \frac{E}{h(\log k_\infty + \log u - \log (uk)_m)^2} = \frac{R}{(\log e)^2 \ln(k_2/k_1)} \quad (2)$$

where k_1 and k_2 represent the rate coefficients at the beginning and end of the halfwidth h (as a special temperature difference $T_2 - T_1$). The quantity M has the same dimension as the gas constant R . As an approximation, the logarithmic ratio of these rate coefficients is, for an elementary process of n -th order, a constant quantity, and for unit starting concentration represented by

$$\ln(k_2/k_1) = 2.25n^{0.52} \quad (3)$$

Generally, any characteristic time or temperature difference of this type satisfies an expression

$$\Delta T = T_2 - T_1 = m(t_2 - t_1) = mu \ln(k_2/k_1) = w \ln(k_2/k_1) \quad (4)$$

if k_2 and k_1 are the respective rate coefficients. (The errors in this approximation increase with increasing order and increasing temperature interval.)

Moreover, it is known since the pioneering work of Kissinger that, apart from the M index defined by eqn. (2), the shape index S [11,13,20,21] is also specific to the reaction order and for complex reactions specific even to the type of reaction mechanism.

Heat feedback, DTA and Semenov's Theory of Self Ignition

DTA under "all-liquid" conditions (stirred system, temperature tracer within the solution) is the most general technique which allows the confirmation of postulated relationships in non-isothermal reaction kinetics. However, the reaction temperature must reveal deviations from the desired course linear to time (= heat feedback, FB) when power-compensating techniques are excluded.

Even for DTA, it is essential to consider the influence of the cell constant c with a view to the determination of the mechanistic coordinates, M and S . This problem has been solved for homogeneous solutions under the assumption of a one-step reference process (see "uc-theory" [22,23]).

For the FB effect, interesting and useful relationships are available from Semenov's Theory of Adiabatic Self-Heating of Gases [24,25]. In the case of a DTA signal $\theta(t)$, the validity of an equation such as eqn. (4) may be discussed twice: both for the time (or temperature) axis, and for the signal itself. Semenov has used an equation exactly like eqn. (4) for the temperature rise of a self-heating gas from a starting temperature T_0 to a critical temperature T_2 in order to decide whether such a reaction gas will remain thermally stable or not. Using eqn. (1) for $w = m \cdot u$ with T_0 instead of T_1 , and unity for the heating rate m , an unlimited temperature increase, i.e. an explosion, must occur if $\Delta T/w > 1$. Similarly, we could confirm that (apart from the term uc , needed for the elimination of the thermal lag) even a standardized maximum temperature difference, θ_m/w , must be used for the correction of the half width and shape index of a DTA-curve, in order to refer these quantities to the corresponding rate curve [11,12,22,26,27].

COMPLEX PROCESSES

In homogeneous reaction kinetics, the time dependence of an appropriate physical quantity $y(t)$ may, for the case of proportionality of $x_i(t)$ to the kinetic fluxes in the p steps ($i = 1 \dots p$) of the reaction model, be formulated [8,28,29,30] as

$$y(t) = \frac{dx}{dt} = \sum_{i=1}^p \lambda_i k_i [T(t)] \Pi_i(t) \quad (5)$$

where λ_i = total change of x for the respective method (weight-indication- or signal-parameter); k_i = rate coefficient; Π_i = concentration or product of two concentrations (uni- or bi-molecular) for step i ; $T(t)$ = temperature program.

This equation is adapted to the use of computers since it utilizes the representation of a reaction mechanism by a reaction matrix [31]. It involves nearly all methods of thermal analysis; even DTA when $y(t)$ is equated to the total heat flow [8,32,33] which for an "all-liquid" apparatus (temperature-dependent heat capacity C_p and kinetic cell constant c) can be obtained from the temperature difference sample/reference, using the Tian temperature-balance equation [33,34] (= calorimeter equation)

$$\frac{d\theta(t)}{dt} = \frac{1}{C_p} \sum_{i=1}^p \frac{dq_i}{dt} - c\theta(t) \quad (6)$$

Theoretical access

Equation (5), based on a linear superposition of individual kinetic fluxes, is one basic source for signal pre-calculations of complex processes. Hence, the peculiarities of the special types of mechanism can be studied in detail [16,18,19]. There are powerful integration programs which allow a comparison of the temporary signal evolution of an assumed reaction mechanism with that of a real process. These even overcome many of the difficulties stemming from "stiff" problems, i.e. a dramatic increase of the calculation times when the rates in related branches of the scheme are different by orders of magnitude [35,36]. Very much has been done to adapt such programs, initially developed by mathematicians, to the practical needs of the chemist [37-41]. Expansion of the respective subroutines for linearly increased temperature involves no principal problems once the validity of a rate law (as in eqn. 5) and of the Arrhenius equation for the k_i 's have been confirmed also for such conditions [7,11,12,23,42-47]. The consequent use of this equation, with our VAX11 computer as a tool, has led to more and more rules and constraints, which are consistent with the results of various isothermal and temperature-programmed experiments in solution.

For the creation of such material for revealing and understanding new phenomena in non-isothermal reaction kinetics, we have developed the integration program METEX, starting from analog computer studies in 1972 [23,30,46,48,49] which allows the direct input of an assumed reaction mechanism (scheme 1; up to 20 steps).

Nevertheless, such a program is not sufficient to determine directly the best model for an experimental curve or a series of such curves. Even if this model would have been found, the time expenditure for fitting all data is very high. The computer needs an algorithm for an optimum variation of the data, which, however, must again depend on certain properties of the

Scheme 1 Computer programs

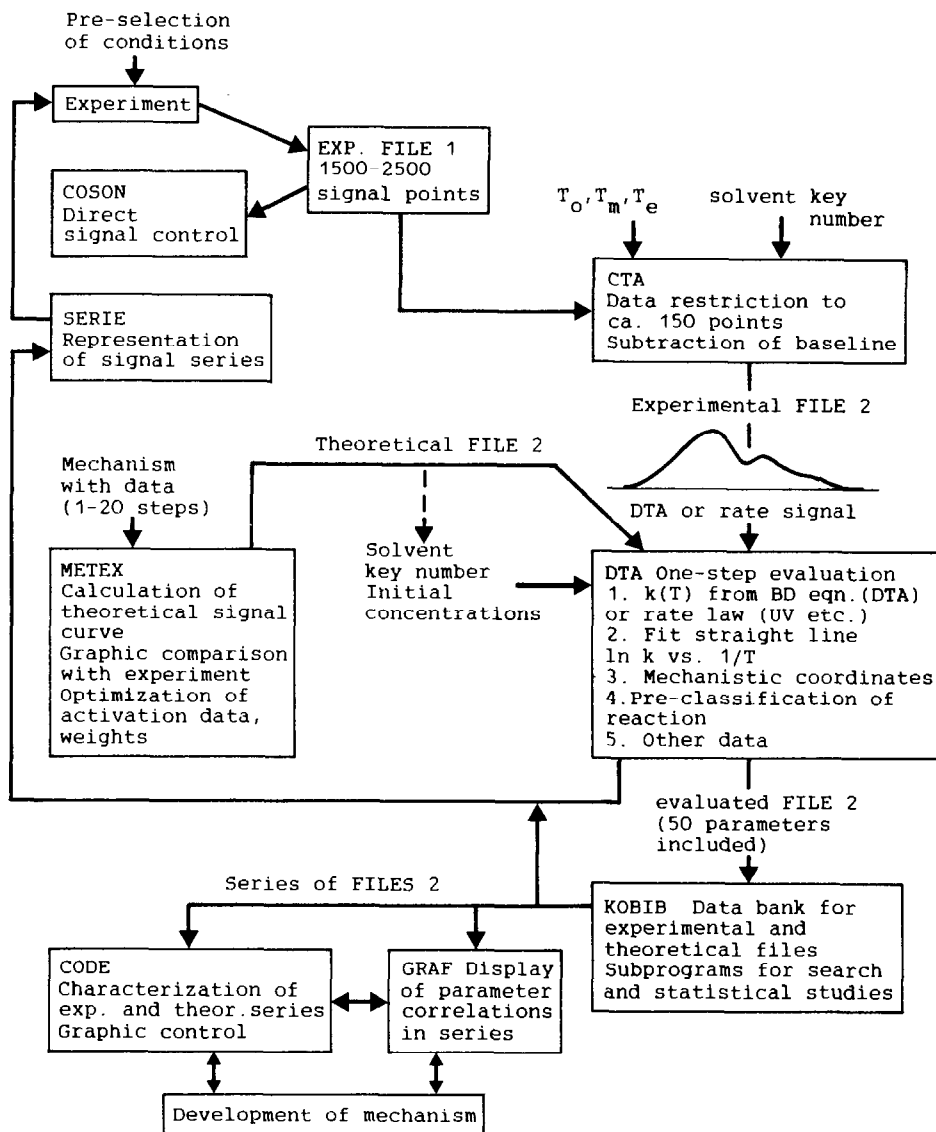

Scheme 1. (Capital letters are used for program names.)

mechanism. It seems greatly inefficient [40], for example, to adapt the 60 parameters of many alternative 20-step mechanisms to some special TA curves, even when this number can be reduced essentially by thermodynamical restrictions (i.e. $E_2 = E_1 - \Delta H$ for two opposing reactions). Only a well-founded assumption or literature knowledge of the data of special steps may help. An integration program represents a really powerful instrument, but its use should not be restricted to the trivial procedure of reproducing

experimental curves based on questionable mechanisms. However, its use is much facilitated by the relationships evolving from the Theory of Characteristic Rate Coefficients.

Advantages of standardization

Hence, quantities were required which are characteristic of the prevailing mechanism, but mainly independent of the special E_i , $\log k_{\infty i}$ and λ_i values of the steps occurring in eqn. (5). Shape index and the reaction type index meet this condition if the process is elementary; in general, theory indicate characteristic differences to an elementary reference process. Whilst the shape index is directly available from the tangents of inflection, the M -index has to be referred to a reference reaction; we prefer either the best-fitted initial or overall reaction [19,23,46].

For DTA, it is in any case advantageous to first assume an elementary model, because the specific time is needed to refer both source data (shape index and halfwidth) to the ideal rate curve. This type of work is a good example of the transfer of a tedious job to a computer; these theoretical calculations have led to working formulae which then were confirmed by more than 1000 experiments [10,22,26,48].

Thus, to discuss the two mechanistic coordinates for an experiment, the standardization of the evaluation procedure, as the most logical approach to the model-search, implies first assuming a one-step process in order to obtain apparent activation parameters and the corresponding specific time. In complex reacting systems, these cannot have any direct physical meaning, but allow us to calculate the mechanistic coordinates. This is evidently useful for a subsequent mechanistic classification, on the basis of pattern recognition [7,19,29,50].

Theory, experiment and computer

The strategy described, looking at the deviations of S and M from their "elementary" values, may be applied analogously to theoretical curves. These are generated for an assumed mechanism by an integration program, constructed in the usual way by setting up the corresponding system of differential equations [23,31,35], and then formulating an equation such as eqn. (5) for the derivative overall signal. The λ_i 's have to be selected according to the method applied, i.e. reaction enthalpies for DTA, products of extinction differences with optical path length for reaction spectroscopy, mole number for TG etc. [28]. Then, the resulting theoretical plots can be evaluated by the same program as used for the experimental plots.

Hence, we have developed a computer package consisting of a data bank with experiments (incl. results, divided into sublibraries, specified for various classes of substances), evaluated theoretical runs, programs for on-line

storage of runs, evaluation, simulation, graphic representation (of curves, fits of theoretical curves, experimental and theoretical series, or any correlations of parameters), and fixations of such correlations by codes (Scheme 1) [7,8,29,48,49].

MECHANISTIC DIAGNOSIS BY PATTERN RECOGNITION

In the principal strategy for the model determination, both theoretical and experimental signal curves are subjected to the same evaluation procedure (Scheme 2).

Hence, it is possible to find the specific ranges of the mechanistic coordinates S and M for a certain mechanism which must be represented by

Scheme 2 Strategy of model search

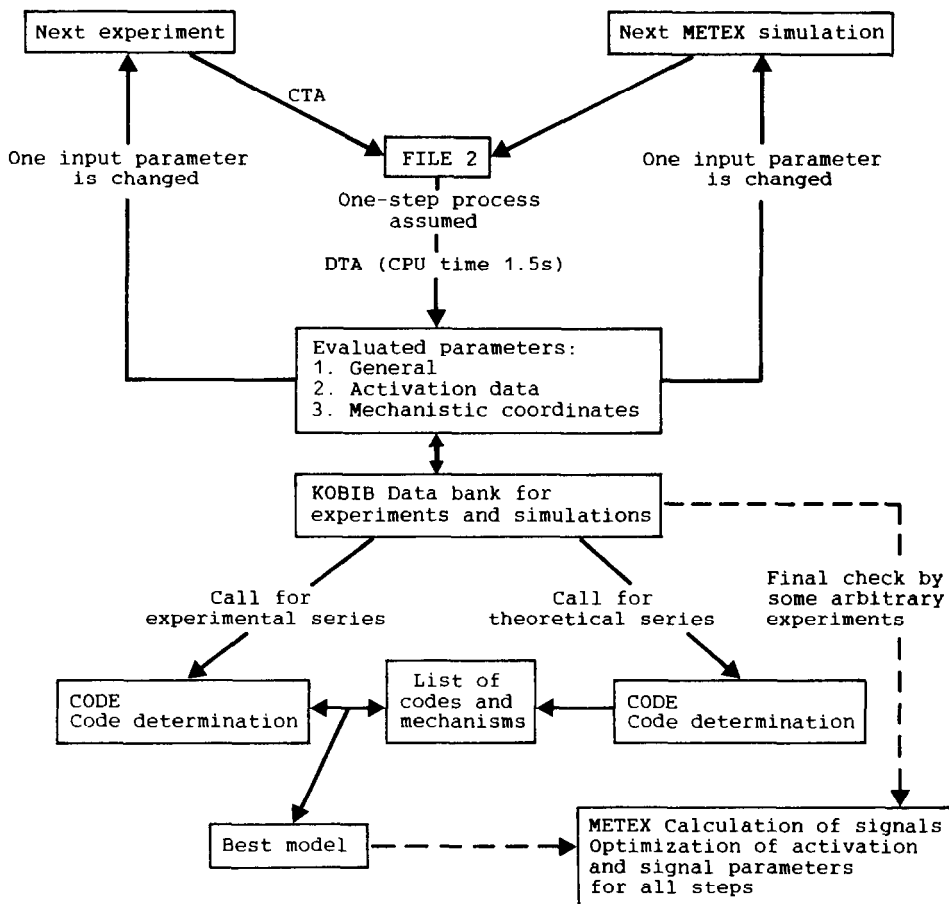

Scheme 2.

TABLE 1

Examples of theoretical concentration codes

Mechanism ^a	Normal and simplified concentration code ^b		Number of C-periods	Remarks
	S	M _{overall}		
G ₂₁ $E_2 = 8; F_2 = 6$ $\lambda_1 = 10; \lambda_2 = -10$	+H-2	2+ -L	2	Influence of sign of $E_2 - E_1$
	V H V 2	2 W L		
$E_2 = 25; F_2 = 18.8$ $\lambda_1 = 10; \lambda_2 = -10$	L + + 2	M - (M)2	2	cf. Fig. 1b
	L V 2	M V 2		
P _{1a} $E_2 = 18; F_2 = 14$ $\lambda_1 = 10; \lambda_2 = 5$	1 1 + - 1	1 + (L) - M	2-3	Influence of activation energies
	1 W 1	1VLVM or 1WM		
$E_2 = 22; F_2 = 18$ $\lambda_1 = 10; \lambda_2 = 5$	1 1 + - 1	1 + (L) - 1	2-3	cf. Fig. 1a
	1 W 1	1VLV1 or 1W1		

^a $E_1 = 15$ kcal/mol; $F_1 = \log(A\text{-factor}) = 12$ (units mol, l, min).

^b Normal codes: see Fig. 1a-c, Symbols of simplified codes: V = variable (monotonous); W = variable (extremum value); 1, 2 = correspond to first or second order; () = probably constant; ? = not investigated in this concentration range.

a mechanistic region in the S/M diagram. Indeed, I have elaborated a "mechanistic map" for all possible two-step models by the computer [7,19,30]. In contrast to the simplified concentration codes (see Table 1), the positions of the mechanistic points depend on the activation data (alternatively, on the specific time and on one characteristic temperature) of the second reaction, compared with the respective data of the first reaction (= reference reaction). Using $E_1 = 15$, $(\log A)_1 = 12$, and $(\log A)_2 = 4, 6, 8, 12$, the second activation energy was varied in steps over the total range of interaction of both processes in order to obtain a reliable characteristic map. This required 50-100 simulations for each two-step model.

Conversely, the authors and co-workers performed a preliminary kinetic classification of our ca. 2500 individual experiments, using our routine evaluation program [7,23,46,48]. However, such a classification, when it is based on one experiment only, cannot be very selective; for small degrees of complexity, i.e. one poorly distorted process, there is an overlap of the regions of all mechanisms near to the respective elementary S/M point [7,18,19].

Nevertheless, this simplest mechanistic analysis may be useful, especially for reactions involving only steps of the same order, or for heterogeneous reactions, where the regions are in general much smaller and must not include the elementary points of first and second order, which means much higher selectivity [19,48].

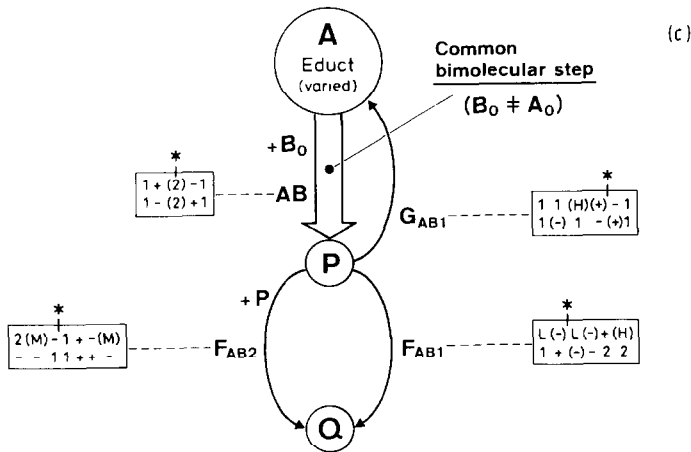
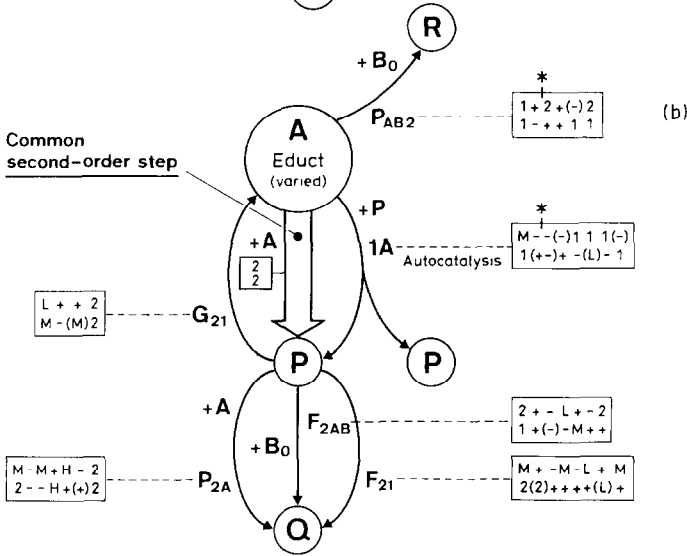
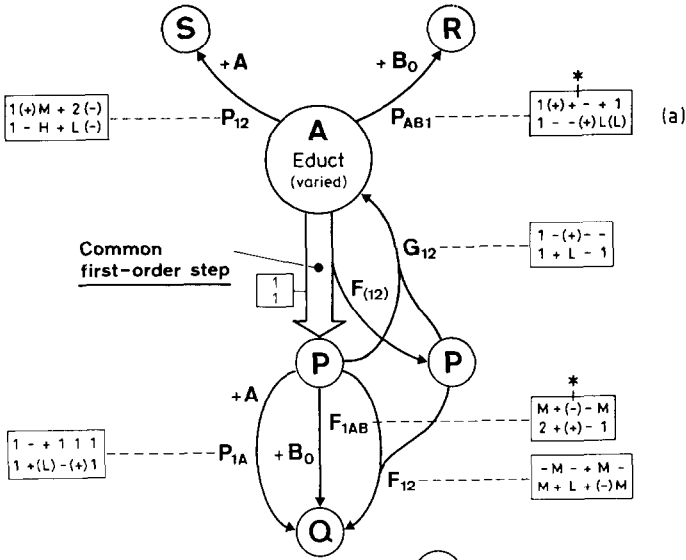

CONCENTRATION CODES

A detailed kinetic study has to consider the influence of the initial concentrations of the reactant(s), possibly complemented by those of accelerators, catalysts, scavengers, inhibitors, other transients or final products. In order to utilize the capability of a computer, such effects may be characterized by a series code, i.e. a chain of symbols representing behaviour types of a "response quantity" as a function of an independent "transmitter quantity", in this case even the initial concentration of a reactant (see Fig. 2)

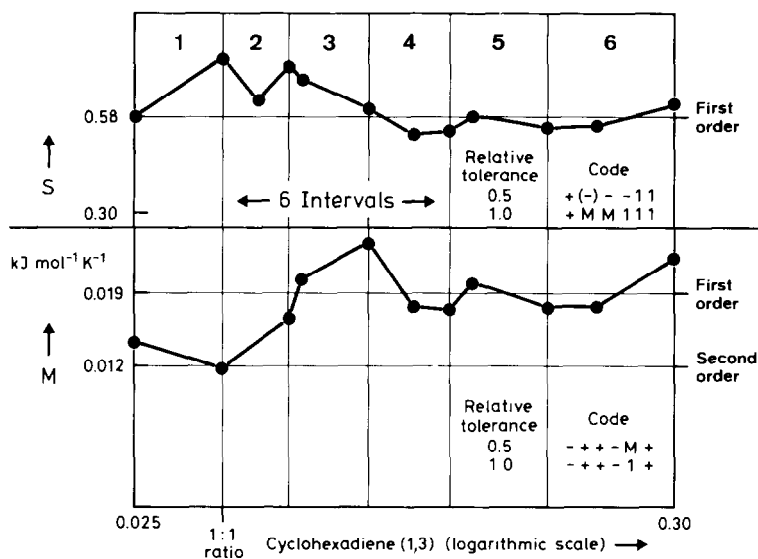

Fig. 2. Examples of experimental concentration codes. Twelve experiments with the system 0.05 M cyclohexadiene-(1,3) + (O_{Ph})₃PO₃ (varied) in 1.25 M aq. H₂SO₄. Interval widths on the logarithmic concentration axis calculated by the computer (program CODE) on the basis of the *M*- or *E*-values; uniform for all parameters. For the determination of the adequate symbol in one code interval, at least two experiments (or simulations) are necessary. Therefore, the number of runs in a series should be much higher than the number of selected intervals, especially for high error limits. Dimensions; kJ, mol, min, K; symbols, see Fig. 1.

Fig. 1. Two-step models and their mechanistic concentration codes for an overall reference reaction. (a) First-order source reaction. (b) Second-order source reaction ($A_0 = B_0$). (c) Same, but $A_0 \neq B_0$. Approximately twenty simulations per model; assumed activation data and λ -values; See Table 1. Codes: For S (first line) and M (second line) Sub-specification (corresponding orders n): L: $n < 1$; M: $1 < n < 2$; H: $n > 2$. Calculation of n from M; eqns. (2) and (3); from S: ref. 11. Symbols for mechanisms: cf. text [19,48]; the indices are the reaction orders for both steps. First index: for types F, G related to initiating reaction = reference reaction; for types P related to the order of the reference reaction assumed, a = reaction of final product with educt, * = mark for reactant ratio 1:1.

for example, (+ - C +) should indicate: increase for smallest concentrations, then decrease for enhanced, medium concentrations, then constant, and finally increase again towards the highest concentration used in the series.

In non-isothermal kinetics, promising parameter candidates for the model search are: initial temperature; peak temperature; final temperature; peak height (referred to initial concentration); overall reaction enthalpy; shape index; reaction type index. In a statistical study based on 15 response parameters and 25 different series, it was confirmed that the latter two candidates, even the mechanistic coordinates, are the best [8], whilst any characteristic temperature, together with the relative signal height, represents another type of fingerprint [49,51]. The latter is useful if a kinetic evaluation based on the one-step strategy is difficult or impossible (e.g. because of resulting negative reaction coefficients [46]).

The concentration codes of the mechanistic coordinates S and M reveal, especially if they are simplified [29] to the symbols: c = constant, v = variable/monotonous, w = extremum value, i.e. combination of + - or - +, two remarkable features (Table 1). First, for a prevailing reaction mechanism, these codes seem, indeed, to be nearly independent of the activation data of all participating processes; exclusively a sign inversion of the differences of two activation energies of steps involving the same species may change the total code. A simple example may illustrate this. In a simple mixed-order opposing reaction, e.g. $A \rightleftharpoons B + C$ (abbreviation G_{12}), we have two cases. In the case $E_2 < E_1$, only one endothermic peak appears for this mechanism, whereas for $E_2 > E_1$ two possibly overlapped peaks (one exothermic, then one endothermic [16]), i.e. different codes are obtained [29] (Table 1). Second, constant values of both coordinates in the same concentration interval signal a rate-determining step. Apart from the invariance in the first, last and, possibly, other intervals, the absolute values of the parameters are typical for the limiting cases of the reaction mechanism involved [15] (see subdivision of C into L, 1, M, 2 and H in Tables 1, 3 and Fig. 1a-c). These statements are meanwhile confirmed by the codes of ca. 170 experimental series, stored in our data bank (see scheme 1 [8,48]) and based on very different chemicals.

THE STEP FROM n TO $n + 1$ REACTIONS

For increasingly complicated mechanisms, the pattern recognition method, based on the comparison of appropriate codes for all imaginable models, must find its natural limit in the enormously increasing number of combinatorial possibilities. Considering two reactions, the storage capacity needed is relatively small; for three reactions, the expenditure may be increased by a factor of 20 or 30, but this is really no problem for a personal computer

Even the various possibilities for four reactions may be governed if the storage capacity is in the megabyte range. However, the question arises as to whether this kind of approach to the model search is really appropriate; for example, in isothermal studies of the Belousov–Zhabotinskii oscillating reaction, 20 steps are discussed [52,53]. The problem seems to be related to

TABLE 2

Comparison of move sequence search in chess with model search in chemical kinetics

	Chess	Kinetics
TEMPORARY DATA	Material value	Concentration of species
	Position value + time value	Kinetic weight of this species, i.e. its contribution to the derivative signal
ANALOGIES	Search depth	Number of reactions
	Position picture	Position of a situation-related point in the mechanistic diagram
	Further move	Further reaction
	Chess rules	Mass Action Law and thermodynamic restrictions
A-strategy	All plies up to a moderate search depth are examined.	All models up to the limited step number are examined.
Brute force	Decision preferentially by the material value.	Decision by comparison of the codes (originating from the concentration plots).
Disadvantage:	Longer move sequences are disregarded.	Less relevant steps due to a more complicated mechanism are disregarded.
B-strategy	All plies up to a smaller search depth than above are examined.	All models up to a smaller step number than above are examined.
Selective	Special final nodes are pre-selected for extrapolation to a much longer move sequence than in the A-strategy.	More details are revealed by assuming extended models, stemming from special studies or literature.
Disadvantage:	Time-consuming valuation tests are required. Possible nonoptimized moves by disregarding un-conspicuous, but unfavorable early moves.	Possible incorrect interpretation by also disregarding relatively simple basic models.
C-strategy Adapted to human mode of thinking	Compromise of A and B strategy. Substitution of valuation algorithms by a comparison with numerous tested position pictures.	Compromise of A and B strategy. Additional comparison of the placement of the mechanistic points with the regions of numerous tested models.

that of a chess computer [54,55] (Table 2). Machines operating with a search depth of 3 or 4 plies, which require 2 or 3 minutes per move, are commercially available even as pocket computers. However, the biggest computers such as the "CRAY" do not exceed a basic search depth of 8 or 9 plies within this time if all move possibilities are to be examined. Primarily, programs were tested using a fixed search depth (brute force method, A-strategy) which examined all possibilities, but soon led to unrealistic data storage requirements. Then a pre-selection, beginning at the second or third node, was introduced (B-strategy) in order to restrict the examination of later moves to probable possibilities. Modern endeavours aim at the parallel use of a memory in which thousands of investigated chess positions are stored, together with their valuation factors (C-strategy). The reason is that a human chess champion obviously does not follow all imaginable deeper move sequences; he finds the best move by a comparison of those chess positions resulting after a few moves, with numerous positions known to him, and stored in his mind in the form of position pictures.

Such a strategy corresponds closely to the mechanistic map diagnosis for a model search in kinetics. Let us first consider the analogy to the brute force method, i.e. all possible expansions from n to $n + 1$ reactions. How do the mechanistic concentration codes change if a further reaction is appended to a reaction scheme?

This question can be answered for the simplest kind of extension, that from one reaction to two, since the concentration codes of all two-step models were determined by computer simulations. For the sake of simplicity, a first-order reaction may be primarily selected as a basis. For the different kinds of reaction couples, P_{1X} (competing reactions), F_{1X} (consecutive reactions), and G_{1X} (opposing reactions), the resulting concentration codes are presented in Fig. 1a-c for $X = 1, 2$ and AB (rate law of first-order, second-order and bimolecular, $A_0 \neq B_0$). Compared with a simple unimolecular process (code 1), the number of concentration ranges with symbols 1, 2, L, M, H or C is raised from one to two or more. Two such periods usually appear at the ends of the total concentration interval, i.e. for the highest and the lowest concentration. The corresponding limiting concentrations depend both on the sensitivity of measurement and on the ratio $E_1(\ln k_{\infty 2} + \ln u_2)/E_2(\ln k_{\infty 1} + \ln u_1)$, involving the activation parameters of both steps and containing additional concentration terms for bimolecular reactions [9,10,12,14,16]. If this ratio is unity, then there are no temperature effects. Similarly, in the case of models with steps of equal order, concentration effects are not expected. Formation of a relevant code with several symbols then requires variation of another transmitter quantity, the heating rate [15,19,48].

A route to the other two-step models is substitution of the initial unimolecular step by a bimolecular step, and addition of a subsequent unimolecular step (Fig. 1b,c). Also to be considered are some special reaction

TABLE 3

Concentration codes of some experimental series and two-model codes

System, molarity and solvent or mechanism	Normal and simplified concentration code		Number of C-periods	Remarks/ref.
	S	M _{overall}		
Cyclohexadiene(1,3) + 0.05 (PhO) ₃ PO ₃ in CH ₂ Cl ₂	?+M(-)I I I ?V M V I	?-+ + -1+ ?W W 1 V	1-2	Competing reactions; cf. Fig. 2 [49,58] cf. Fig. 1
P _{AB1} E ₂ = 20; F ₂ = 16 λ ₁ = 10; λ ₂ = 15	1(+)+ -+ +1 1 W W 1	1 - -+ L(L) 1 W L V	2	
Ce(SO ₄) ₂ + 0.025 malonic acid + 1.25 aq. H ₂ SO ₄	+ + (H) - (M) - 1 W (M) V I	1(+)+ - (1) W (M) V I	2-3	Partial reproduction by 7-step model [43]
MAC7A	- - - - 1 - - V 1 V	1 - (2)+ 1 or 1 W I	1-3	
NaIO ₃ + 0.58 H ₂ O ₂ in H ₂ O	(-) + 1L + 1(+) (w)V L V 1(V)	- (-) - 1(+)- 1 - V 1 (W 1) V	2	Addition of further reactants in order to construct an oscill. Briggs-Rauscher System [60]
Same; addition of 0.001 MnSO ₄	? - (L) + (1) + M ?V L V 1 V M or ? W M	?LL + - LL ? L W L	1-2	
Same; addition of 0.005 MnSO ₄ and + 0.03 malonic acid	- L2 + (H) - 2 V 2 V H V 2 or V 2 W 2	L(L) - + (1) - M + L W 1 V M V or L W W M V	2-3	

See footnotes to Table 1.

types which are characterized solely by one activation energy and one A factor, such as the normal bimolecular reaction and the bimolecular autocatalytic reaction ($A_0 \neq B_0$). These types reveal limiting first-order cases for either very low or very high starting concentration of component A in Fig. 1a (= pseudounimol. case) and one or two limiting values of one or both mechanistic coordinates between the concentration barriers.

For nearly all two-steps models, constant periods appear at both ends of the code; the absolute values of the mechanistic coordinates correspond to orders of 1, 2 or other values (see legend to Fig. 1a-c). It is the additional consideration of these values which shifts the procedure to the "C-strategy". The superiority of the simplified and mostly, also of the detailed mechanistic codes for the classification of mechanisms is reflected both by their independency of an accidental situation, specified by the activation parameters (Table 3), and merely a moderate influence of the signal parameters. Whereas such parameters as signal height or area (e.g. overall enthalpy for DTA) may be strongly influenced by or even proportional to the λ -parameters, so that the respective concentration codes may reveal drastic changes (as exchangeability $+/-$), reaction type index and shape index are much less sensitive to variations of the ratio λ_2/λ_1 [28,51]. The influence of λ on these kinetic data is similar to that of the starting concentrations; only in the case of participating bimolecular steps will there be a moderate shift of the S and M data in the intervals of invariability. For M, this will be proportional to the ratio [9,14]

$$\left[\frac{\ln k_{\infty 1} + \ln u_1 - \ln(k_{m1} A_0 \cdot \lambda_1)}{\ln k_{\infty 2} + \ln u_2 - \ln(k_{m2} A_0 \cdot \lambda_2)} \right]^2$$

Therefore, if a change of the sign of $\lambda_1 - \lambda_2$ (or $E_1 - E_2$) is excluded, the influence of the ratio λ_2/λ_1 on the code may be neglected for a definite mechanism. Occasionally, the moderate change, especially of the absolute overall-referred values of M, may lead to an ambiguity between the symbols L, 1, M, 2, and H in later code intervals characterized by a bimolecular and rate-determining second step. Such features make the mechanistic concentration codes universal for nearly all TA methods.

It would exceed the scope of this article to discuss the results of only one experimental example of our concentration series in full detail. This has already been done [43], and further examples are discussed in forthcoming contributions which confirm that the approach is promising [56]. For some examples, the concentration codes are listed in Table 3. In the reaction between triphenyl phosphite ozonide and cyclohexadiene-1,3 in CH_2Cl_2 , the bimolecular reaction between the components begins at 180 K, partially leading to the endoperoxide [57,58]. The reaction is distorted by the unimolecular decay of the phosphorus compound, according to the mechanism P_{AB1} in Fig. 1a. However, there are some kinetic and preparative indications for further side processes. The oxidation of malonic acid by ceric sulphate

may serve as a more detailed example for the new approach [43]. This process, and the reaction between iodate and hydrogen peroxide are basic constituents for oscillatory systems [59,60]. Even in the field of chemical kinetics, the code-directed application of TA methods leads to fascinating and, partially, new results [48,49,56,61].

CONCLUSION AND OUTLOOK

The purpose of a model search program is to find out a mechanism which describes the kinetics of a reacting system satisfactorily, whilst the purpose of a chess computer is to win a game. However, to succeed in winning, it is necessary to have an optimum view of the present situation, which enables "one" to extrapolate to future situations. Since exactly these capabilities are also expected from an adequate reaction mechanism, and since chess computer programs are considered as an optimum training vehicle for artificial intelligence, let us try to draw conclusions from the results of our analogy (Table 2).

Neither the procedure analogous to the A-strategy, i.e. the approach to the kinetics by checking all possible mechanisms with a fixed, but too small (= over-simplified) number of steps, nor the analogue of the B-strategy, i.e. additional test of all simpler, but also of some more complicated mechanisms (whose correctness can usually scarcely be strictly confirmed!), are really satisfactory, although both variants are frequently applied for kinetics in solution. However, if we compare those kinetic situation pictures given by the extended concentration or heating rate codes [15,16,8,29], with those of models [43] (C-strategy), ambiguities in the kinetic interpretation may be restricted. If the comparison reveals lack of agreement in the sense that the number of code intervals assumed is too small, a refinement is reached by addition of further steps, which should expand the code as demonstrated by Figs. 1a-c.

The author's present intention in practical model searches is not mainly to find out the mechanisms of unexplored systems, but rather to test the reliability of the universal concept based on eqn. (5) with complicated, but well-known reacting systems. If the idea of mass-action based kinetics in homogeneous solution is correct, and if for any method additivity of the kinetic fluxes in all branches of the reaction scheme, formulated via the signal parameters, λ_i , is guaranteed, then no objections can be raised against using eqn. (5) for the evaluation of kinetic response curves. Moreover, this equation must also be applied for the calibration of the λ_i 's regarding the stationary case $t \rightarrow \infty$, i.e. for providing structural instead of kinetic information [1,28]. The application of more structural-sensitive methods, which are more capable of the direct identification of intermediates, may complement the DTA technique and reflect the same kinetics from the new perspective of altered signal parameters.

Conversely, a model-search expert system may also utilize isothermally gained structural information from the literature, e.g. in the form of spectra $\lambda = f$ (wavelength) for the expected intermediates. But a true self-learning capability, expressed by mutual simulation of signal series, evaluation of experimental signals, calculation of the respective codes, their comparison, and systematic planning of the next series, requires operations with quantities characteristic of mechanism. In response curves obtained merely at one constant temperature, no shape index exists in general, especially for elementary reactions; according to the formal reaction order, only one quantity, specific of the reaction and derived from the half-time, can be discussed. Such a one-dimensional model search [1], based on an isothermal reaction type index, is much less specific and less promising for describing the kinetics of the process.

Unfortunately, eqn. (5) is inapplicable for most solid phase reactions [48,62]. Hence, an important intermediate goal is to develop extended formulations for heterogeneous models, which involve several rate-determining steps and those special geometrically founded concepts which are characteristic for mechanisms in this field [63,64]. Whenever such a general equation exists, the computer may generate a framework of parameter codes of heterogeneous mechanisms which yields new material for the development of such classification rules as have become so useful in homogeneous reaction kinetics [31,65].

ACKNOWLEDGEMENTS

The kind and continuous promotion of my kinetic studies by Prof. Dr. O.E. Polansky and Prof. Dr. P. Potzinger, and the cooperation with my coworkers, Mrs. B. Pirke, Mr. N. Belau and R. Laupert, are gratefully acknowledged. Special thanks are devoted to the joint computer department of the Max-Planck Institutes for Radiation Chemistry and Coal Research, especially Dr. E. Ziegler, K. Boll, H.-D. Schmitz and W. Angenendt, who wrote the program for the code generation.

REFERENCES

- 1 E. Koch, *Non-isothermal Reaction Analysis*, Academic Press, London, 1977.
- 2 M. Mesarovic and E. Pestel, *Multilevel Computer Model of World Development Model*, Extract of the Proceedings Laxenburg (Austria), 29.4-3.5.1974, I IASA-SP-74-06.
- 3 Y.V. Cheban, S.-F. Lau, and B. Wunderlich, *Colloid Polymer Sci.*, 260, (1982) 9; S.-F. Lau and B. Wunderlich, *J. Thermal Anal.*, 28 (1983) 59.
- 4 P.K. Gallagher, *Thermochim. Acta*, 90 (1985) 115.
- 5 W.W. Wendlandt, *Thermochim. Acta*, 5 (1973) 225.
- 6 B. Wunderlich, *Thermochim. Acta*, 83 (1985) 35.

- 7 E. Koch, in K.H. Ebert, P. Deuffhard and W. Jaeger (Eds.), *Modelling of Chemical Reaction Systems*, Springer, Berlin, 1981, pp. 216–225.
- 8 E. Koch, *Thermochim. Acta*, 49 (1981) 25.
- 9 E. Koch, *Thermochim. Acta*, 112 (1987) 81.
- 10 E. Koch, *J. Thermal Anal.*, 32 (1987) 259.
- 11 E. Koch and B. Stilkerieg, *Thermochim. Acta*, 17 (1976) 1.
- 12 E. Koch and B. Stilkerieg, *Thermochim. Acta*, 27 (1978) 69.
- 13 H.E. Kissinger, *Anal. Chem.*, 29 (1957) 1702.
- 14 E. Koch, ref. 1, (Chap. 3) pp. 90–126.
- 15 E. Koch, ref. 1, (Chap. 6) pp. 248–319.
- 16 E. Koch, ref. 1, (Chap. 4) pp. 127–173.
- 17 E. Koch, ref. 1 541–547, pp. 58–61.
- 18 E. Koch, *Angew. Chem.*, 85 (1973) 381; *Angew. Chem. Int. Ed. Engl.*, 12 (1973) 381.
- 19 E. Koch, *Thermochim. Acta*, 56 (1982) 1.
- 20 H. Anderson, D. Haberland, and E. Witte, *Z. Chem.*, 18 (1978) 153.
- 21 H. Jüntgen and K.H. van Heek, *Fortschr. Chem. Forsch.*, 13 (1969/1970) 601.
- 22 E. Koch, *Thermochim. Acta*, 82 (1984) 293.
- 23 E. Koch and B. Stilkerieg, *J. Therm. Anal.*, 17 (1979) 395.
- 24 N.N. Semenov, *Chemical Kinetics and Chain Reactions*, Oxford University Press, London, 1935.
- 25 N.W. Bazley and G.C. Wake, *J. Appl. Math. Phys.*, 32 (1981) 594.
- 26 E. Koch, *Thermochim. Acta*, 94 (1985) 43.
- 27 E. Koch, *Thermochim. Acta*, 92 (1985) 253.
- 28 E. Koch, ref. 1, (Chap. 8) pp. 401–533.
- 29 E. Koch, in B. Miller (ed.) *Thermal Analysis Proc. Conf. (7th)*, Wiley, Chichester, 1982, Vol. 1, pp. 71–79.
- 30 E. Koch, *Chem.-Ing.-Tech.*, 44 (1972) 111.
- 31 H. Mauser, *Formale Kinetik*, Bertelsmann Universitätsverlag, Düsseldorf, 1974.
- 32 H.J. Borchardt and F. Daniels, *J. Am. Chem. Soc.*, 79 (1957) 41.
- 33 E. Koch, *Chem.-Ing.-Tech.*, 37 (1965) 1004.
- 34 W. Hemminger and G. Höhne, *Grundlagen der Kalorimetrie*, Verlag Chemie, Weinheim, 1979.
- 35 C.W. Gear, *Numerical Initial Value Problems in Ordinary Differential Equations*, Prentice-Hall, Englewood Cliffs, NJ, 1971.
- 36 S. Pissanetzky, *Sparse Matrix Technology*, Academic Press, London, 1984.
- 37 R.M. Noyes, *J. Phys. Chem.*, 81 (1977) 2315.
- 38 D.D. Warner, *J. Phys. Chem.*, 81 (1977) 2329.
- 39 D. Edelson, *J. Chem. Educ.*, 52 (1975) 642.
- 40 K.H. Ebert, H.J. Ederer and G. Isbarn, *Angew. Chem.*, 92 (1980) 331; *Angew. Chem. Int. Ed. Engl.*, 19 (1980) 333.
- 41 R.J. Field, *J. Chem. Educ.*, 58 (1981) 408.
- 42 E. Koch and B. Stilkerieg, in E. Marti, H.R. Oswald and H.G. Wiedemann (Eds.), *Nicht-isotherme Reaktionsspektroskopie (UV/VIS.) als direkte thermoanalytische Methode*, in angewandte chemische Thermodynamik und Thermoanalytik, Birkhäuser, Basel, 1979, pp. 141–147.
- 43 E. Koch, *Thermochim. Acta*, 101 (1986) 245.
- 44 E. Koch, B. Stilkerieg and L. Carlsen, *Thermochim. Acta*, 33 (1979) 387.
- 45 E.L. Simmons and W.W. Wendlandt, *Thermochim. Acta*, 3 (1972) 498.
- 46 E. Koch, B. Stilkerieg and L. Carlsen, *Ber. Bunsenges, Phys. Chem.*, 83 (1979) 1238.
- 47 J.M. Criado, *Thermochim. Acta*, 43 (1981) 111.
- 48 E. Koch, *Angew. Chem.* 95 (1983) 185; *Angew. Chem. Int. Ed. Engl.*, 22 (1983) 225.
- 49 E. Körös and E. Koch, *Thermochim. Acta*, 71 (1983) 287.

- 50 P. Carter, Material Physics Division A.E.R.E. Harwell, Dec. 1982, HL.80.3872(C₁₄) HMD.
- 51 E. Koch, *Thermochim. Acta*, 76 (1984) 105.
- 52 R.J. Field, E. Körös and R.M. Noyes, *J. Am. Chem. Soc.*, 94 (1972) 8649.
- 53 D. Edelson, R.J. Field, and R.M. Noyes, *Int. J. Chem. Kinet.*, 7 (1975) 417.
- 54 C.E. Shannon, *Philos. Mag.*, 41 (1950) 256.
- 55 P.W. Frey and L.R. Atkin, BYTE Public. Inc. Oct. 1978, 182; Nov. 1978, 162; Dec. 1978, 140; Jan. 1979, 126.
- 56 E. Koch and Zs. Ungvarai-Nagy, *Ber. Bunsenges. Phys. Chem.*, submitted.
- 57 E. Koch, *Tetrahedron* 26 (1970) 3503.
- 58 E. Koch, *J. Therm. Anal.*, 6 (1974) 483.
- 59 U.F. Franck, *Angew. Chem.*, 90 (1978) 1; *Angew. Chem. Int. Ed. Engl.*, 17 (1978) 1.
- 60 S.D. Furrow, and R.M. Noyes, *J. Am. Chem. Soc.*, 104 (1982) 38; 42; R.M. Noyes and S.D. Furrow, *J. Am. Chem. Soc.* 104 (1982) 45.
- 61 E. Koch and B. Stilkerieg, *Thermochim. Acta*, 29 (1979) 205.
- 62 E. Koch, *Thermochim. Acta*, 110 (1987) 135.
- 63 J. Sestak and G. Berggren, *Thermochim. Acta*, 3 (1971) 1.
- 64 P.D. Garn, *J. Therm. Anal.*, 13 (1978) 581.
- 65 R. Schmid and V.N. Sapunov, *Non-formal Kinetics in Search for Chemical Reaction Pathways*, Verlag Chemie, Weinheim, 1982.